



# SIAT

M. J. MAILLIS GROUP

## SK2 / S26

Semi Automatic Carton Sealers

Bottom side application tape



Strong lifting structure



S26



SK2



for more details:



SK2



S26

SK2 and S26 are semi-automatic sealing machines with manual adjustment. Easy to use and simple to adjust, they enable to start the production in just minutes. Thanks to the top and bottom drive belts and the K11R or K12R taping units, they allow the perfect sealing of the box. The machines have been designed in compliance with CE regulation.

> SK2

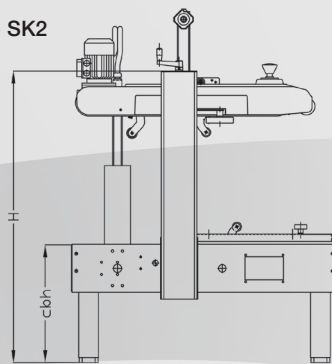

> S26

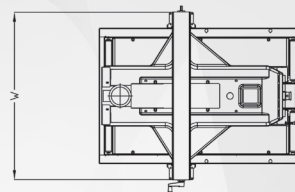
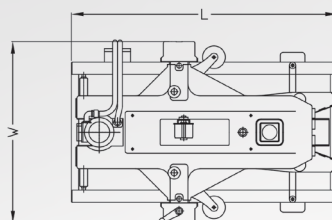
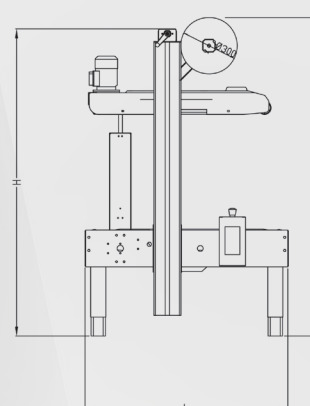

other languages: [www.siat.com](http://www.siat.com)



> Machine dimensions  
Dimensioni macchina  
Machinemessungen  
Dimensions machine  
Dimensiones de máquina

Size / Weigh packaging			LxWxH 
> SK2	160	175	114x78x115
> S26	185	220	133x110x175

> SK2

	Min.	Max
L	1080	-
W	740	-
H	1230	1570
cbh	480	820
AS 77	580	920
AS 80	680	1020

> S26

	Min.	Max
L	1080	-
W	890	-
H	1555	2125
cbh	480	820
AS 77	580	920
AS 80	680	1020

> Taping units  
Unità nastranti  
Verschliesseinheiten  
Unités enrubanneuses  
Unidades de precinto

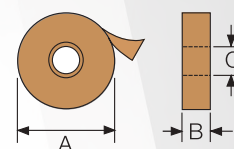

	K11R/ K12R mm
A	410 Max
B	50 / 75
C	76

> Box dimensions  
Dimensioni delle scatole  
Kartonabmessungen  
Dimensions des boîtes  
Dimensiones de cajas

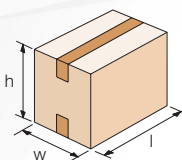

> SK2

	K11R std. / K12R on demand	
	Min.	Max
l	150	∞
w*	140 / 170	500
h	100	500

> S26

	K12R std. / K11R on demand	
	Min.	Max
l	150	∞
w*	170 / 140	650
h	100	950

\* With top side pressure rollers (minimum width manageable 180mm).  
Upper guides required in case of width box less than 180mm (optional).

> Production capacity  
Capacità di produzione  
Produktionskapazität  
Capacité de production  
Capacidad de producción

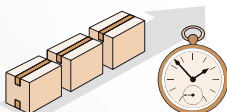

> SK2	Bph
Max pcs.*	1200

> S26	Bph
Max pcs.*	1200

\* Always based on shorter manageable box

> Standard voltage  
Voltaggio standard  
Standardspannung  
Tension standard  
Voltaje estándar

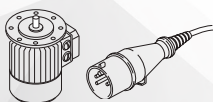

> SK2

380/400V - 50Hz - 3F	
440V - 60Hz - 3F	
Amps	1,08
Power kW	0,26
Phase	3Ph + PE

> S26

380/400V - 50Hz - 3F	
440V - 60Hz - 3F	
Amps	1,08
Power kW	0,26
Phase	3Ph + PE

> Optionals  
Accessori  
Zubehör  
Accessories  
Accesorios

> AS80  
Higher legs  
Set gambe più alte  
Höhere Stützen  
Pieds plus hauts  
Patas más altas



> AS77  
Casters  
Set ruote  
Rädchen  
Roulettes  
Ruedas

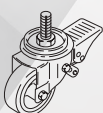

> RG  
Roller conveyor  
Piani a rulli  
Rollenbahnen  
Plans à rouleaux  
Rodillos libres



> GTL - GTR  
Extendable conveyor  
Rulliera estensibile  
Ausziehbare rollenbahnen  
Convoyeur extensible  
Rodillos extensibles

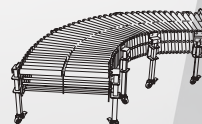

> K-125 / K-250  
Inkjet printer  
Stampante ad inchiostro  
Tintenstrahldrucker  
Marqueur à jet d'encre  
Impresora de inyección de tinta

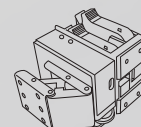

SIAT S.p.A.

Via Puecher, 22 - 22078 Turate (CO) Italy  
Tel +39.02.964951 • Fax +39.02.9689727  
[www.siat.com](http://www.siat.com) • [siat@siat.com](mailto:siat@siat.com)